



YOUR PRODUCT DEVELOPMENT PARTNER

# Vehicle Display Controller

- 3 standard versions available:
  - Optical rotary encoder plus 5 hot keys
  - with or without an 8-way joystick and center pushbutton
- Custom legends & form factors available
- SAE-J1939 compliant
- Sealed to IP67
- Vibration and impact resistant
- Operating Temp: -40°C to +85°C
- Long Life: >500,000 cycles each position
- Support for multiple key combinations
- Dimmable LED backlit legends
- Input voltage: 8VDC to 32VDC

## Put display functions within reach.

- 5 hot keys for rapid navigation
- Scroll with rotary encoder
- Select with pushbutton
- Navigate with joystick



Rotary and Joystick Knob



Rotary Knob only

## ORDERING INFORMATION

PART NUMBER	DESCRIPTION
3J1005-100	Rotary Selection
3J1015-100	Rotary w/ Pushbutton
3J1115-100	Rotary w/ Push & Joystick

**CONNECTION**  
4 pin Deutsch DT Connector. Power with 8V to 32V vehicle type inputs.



Pin	1	2	3	4
Signal	Power	Gnd	CAN_H	CAN_L

## DIMENSIONS in inches (and millimeters)

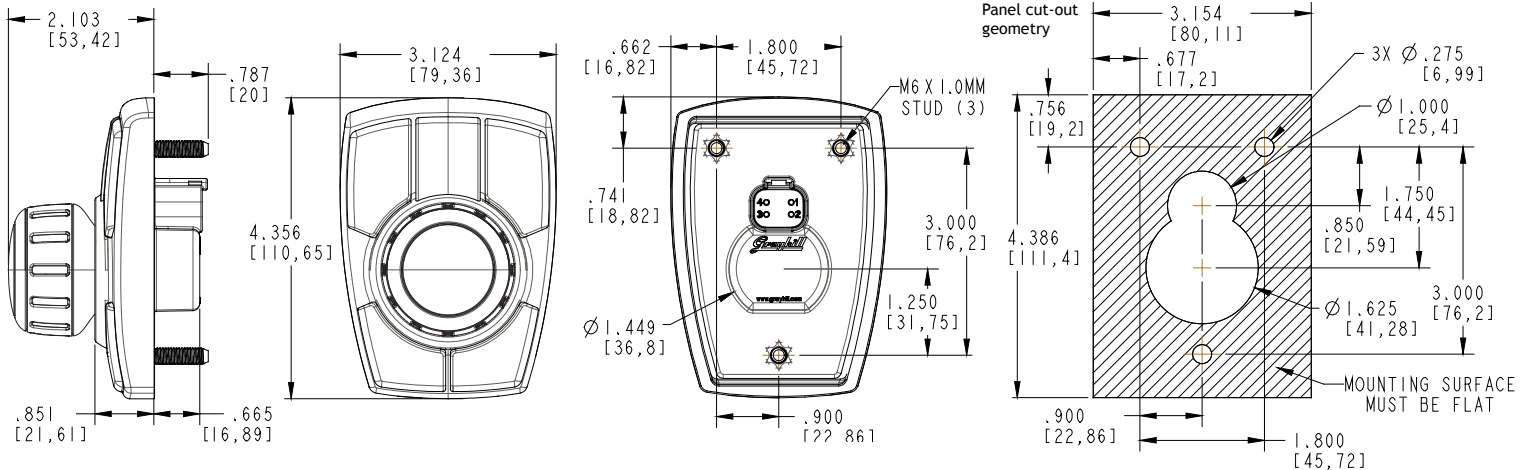

## Your Experts in Cab Controls

Grayhill specializes in the design, development and production of human interface controls, including:

- Cab user interface design
- Customized control panels
- CAN-bus interface devices

Agriculture



Construction



[www.grayhill.com](http://www.grayhill.com)



YOUR PRODUCT DEVELOPMENT PARTNER

ENVIRONMENTAL TESTING STANDARDS		
Operating temperature	ANSI/ASEA EP455 5.1.1 Level 2	-40°C for 4 hours to +85°C for 11 hours
Storage Temperature	ANSI/ASEA EP455 5.1.2 Level 2	-40°C 4 hours to +85°C 4 hours
Thermal Shock	ANSI/ASEA EP455 5.1.3	-40°C to 70°C at a rate of 4°C/min (1 hour at extremes)
Altitude (Barometric Pressure)	ANSI/ASEA EP455 5.2	101.3kPa to 18.6kPa
Sand and Dust	ANSI/ASEA EP455 5.3	24 hours with 0.88g/m <sup>3</sup>
Solar Radiation	ANSI/ASEA EP455 5.4	43 to 75W/m <sup>2</sup> UV Radiation (280 to 400nm wavelength) for 300h
Wash Down	ANSI/ASEA EP455 5.6 Level 2	375 kPa and 8.3 L/min for 10 minutes @ 15°C Water temp
Ingress Protection	IP67	1 meter submersion for 30 minutes
Humidity	ANSI/ASEA EP455 5.13	96% Humidity at 35°C for 240 hours.
Salt Fog	ANSI/ASEA EP455 5.9	5% aqueous solution of NaCl @ 35°C and a pH between 6.5 and 7.2 for 48 hours
Chemical resistance (Resistance to Solvents)	ISO 16750-5 EP 455 (5.8.2)	
Thermal Cycling (Change of Temperature)	ISO 16750-4	-40° to 85°C 2 hours at extremes change rate = 1°C/min (8 hours) repeat for 30 cycles.

ELECTROMAGNETIC COMPATIBILITY STANDARDS		
ESD	ANSI/ASEA EP455 5.12	+/- 25kV for 10 pulses, 5 of each polarity
Radiated Immunity	ISO14982 6.6	10MHz-1000MHz Range 48mA Bulk Current Injection 100V/m
Conducted Emissions	SAE J1113-41, CISPR25	Class 3
Broadband Radiated Emissions	ISO14982 6.4	64dB to 54dB, 30MHz-75MHz (linearly decreases) 54dB to 65dB, 75MHz-400MHz (linearly increases) 65dB, 400MHz-1000MHz

CE COMPLIANCE		
Agriculture and Forestry Machinery EMC	ISO 14982	ESA
Construction Machinery EMC	EN 13309:2000	ESA

PHYSICAL TESTING STANDARDS		
Vibration, Random	ANSI/ASEA EP455 5.15.1	2 hours each axis @ 52.4 m/s <sup>2</sup> RMS overall acceleration and spectral power density of 2m <sup>2</sup> /s <sup>3</sup> from 50Hz to 2000Hz
Vibration, Sinusoidal	ANSI/ASEA EP455 5.15.2	A logarithmic sweep from 10Hz to 2000Hz to 10Hz over a period of 20 minutes for 4 hours in each of 3 orthogonal axes with amplitude of 1.5mm from 10Hz to 40Hz and a constant acceleration of 35m/s <sup>2</sup> RMS from 40Hz to 2000Hz.
Shock / Crash Safety	ANSI/ASEA EP455 5.14	A single 11ms half sine pulse of 490 m/s <sup>2</sup> in 3 perpendicular axes.
Drop	ANSI/ASEA EP455 5.14.2 Level 1	Drop component 400 mm onto a hardwood benchtop on all practical edges.
Shipping integrity	International Safe Transit Agency procedure 3A	

ELECTRICAL PERFORMANCE STANDARDS		
Maximum load	ANSI/ASEA EP455 5.1.1 Level 2	-40°C 4 hours +85°C for 11 hours max load applied
Jump start forward voltage	ISO 16750-2	36V for 60 minutes
Jump start reverse voltage	ISO 16750-2	-36V for 60 minutes
Short circuit protection	ISO 16750-2	All outputs to ground for 60s
Reverse polarity protection	ISO 16750-2	28V for 60s
Starting profile	ISO 16750-2	Class A
Battery-less operation	ANSI/ASEA EP455 5.11.3 Level 2	Apply 6+12.6sin(2*pi*f*t) f is swept from 500Hz to 1.5kHz 5min
Load dump	ISO 7637-2 Test Pulse 5b	Class A
Switching spikes – negative	ISO 7637-2 Test Pulse 3a	Class A
Switching spikes – positive	ISO 7637-2 Test Pulse 3b	Class A
Wire harness inductance	ISO 7637-2 Test Pulse 2a and 2b	Class A
+/- inductive load pulse	ANSI/ASEA EP455 5.11.4	14-300e <sup>-t/0.001</sup> V 1Hz for 300 cycles
+/- mutual coupling	ANSI/ASEA EP455 5.11.6 Level 2	14+200e <sup>-t/14x10^-6</sup> V 1Hz for 300 cycles
Alternator field decay	ANSI/ASEA EP455 5.11.2	Class A

## Custom options available

Contact Grayhill or your local Grayhill sales representative for more information.

Grayhill, Inc.  
561 Hillgrove Avenue  
LaGrange, Illinois 60525  
phone: (708) 354-1040  
fax: (708) 354-2820

[www.grayhill.com](http://www.grayhill.com)

